

Explosion-proof Intercom Station Mentor Orbital 7400 Series



Mentor Orbital 7400 is a Zone 1 certified explosion proof intercom station. The unit operates on a decentralised principle, requires no exchange, special power supplies or external safety barriers.

Connection between stations is a simple 2 wire twisted pair, operational intercom system open architecture allowing a range of interconnection topologies to be configured (e.g. star, loop, radial, spur) 7400/0 can be configured for emergency "Mustercom" service and in this mode critical paths are automatically surveyed. A battery charger is incorporated to float charge an external explosion proof battery where "no break" service is required.

A maximum of thirty two Mentor Orbitals can be assigned when in Mustercom mode and sixty four in operational (unsupervised) mode.

KEY FEATURES & BENEFITS

- ✓ Simplex Push To Talk release to listen or Hands Free VOX switched half duplex
- ✓ Self contained amplification / control logic (No central equipment required)
- ✓ Separate receive / transmit volume controls. Enabling efficient high definition speech in a range of acoustic conditions
- ✓ Hypercardioid microphone. Eliminates background noise pick up
- ✓ Extension re-entrant paging capability
- ✓ 2 Wire operation simple installation
- ✓ Fully integrated processing & amplification, no central equipment
- ✓ Simple installation, very easy system expansion.
- ✓ Selectable hands free or simplex operation - Efficient operation, user friendly
- ✓ Control of external "call" beacon - Enables visual alert in very noisy locations.
- ✓ Large "see in the dark" photo luminescent key pad - Operation by heavily gloved hand
- ✓ Strident paging / calling tone - Alerts site personnel to imminent paging announcement
- ✓ Powerful loudspeaker / amplifier with optional extension paging horn - Audible in very high noise areas
- ✓ 2 wire simple low cost installation & through life maintenance

- ✓ Integral Battery charger - Enables no break service in the event of primary mains failure
- ✓ Separate receive & transmit level controls - Efficient high definition speech
- ✓ Status display matrix window - Enables service without de-energising / opening the station.
- ✓ Fully Zone 1 certified - Requires no provision for safe area "purging"
- ✓ Optional full supervision - Reduces routine testing, ensures system always available.

TECHNICAL DATA

HOUSING MATERIAL/ COLOUR	LM6 Painted to ASTM.B117 / Orange
CERTIFICATION	Hazardous Area Zone 1 Group IIB, T4
INTER STATION CONNECTION	Single Pair Cable (excluding Power) shielded
UNIT CONNECTION	Exd Termination
WEIGHT*	EX7400/0 = 10kg
DIMENSIONS (mm)*	EX7400/0 = 480 x 174 x 120
IP-RATING	Weatherproof IP66
TEMPERATURE RANGE	-40°C to +65 °C
COMMUNICATIONS PROTOCOL	Base Band Audio
POWER SUPPLY	Local / Remote Power Option 24VDC/110-120/ 220-240VAC
FREQUENCY RESPONSE	300 – 6.5KHz
INTEGRAL POWER AMPLIFICATION	20 Watts / 4 ζ
INTEGRAL LOUDSPEAKER	8 Watts / 8 ζ
CONNECTIVITY DISTANCE	3000m @ <90nf

* Dependant on model



MODEL EX7400/0

Explosion-proof intercom station based upon proprietary analogue protocol, which operates without dependency on central equipment.

The two wire analogue connectivity is used for both speech and call tone signalling. This provides optimum reliability and excellent speech clarity and intelligibility. Integral LED array

displays the operational status of the station eliminating the requirement for permits / de-energising the system during first line service.

The key pad is easily operable by gloved hand.

To provide custom facilities for stations, there are options for the addition of a handset or headset, flashing beacon and extension loudspeaker.

	Ex 7400	Ex 7401	Ex 7403	Ex 7404	Ex 7405	Ex 7406	Ex 7407
LOCAL Ex LOUDSPEAKER	✓	✓	✗	✓	✗	✓	✗
LOCAL I.S. KEYPAD	✓	✓	✓	✗	✓	✓	✓
LOCAL I.S. MICROPHONE	✓	✓ (*)	✗	✗	✗	✗	✓
LOCAL I.S. HANDSET & CRADLE	✗	✗	✗	✗	✗	✗	✗
LOCAL I.S. HEADSET	✗	✗	✗	✗	✗	✗	✗
REMOTE I.S. KEYPAD	✗	✗	✗	✓	✗	✗	✗
REMOTE I.S. MICROPHONE	✗	✗	✗	✓	✓	✓	✗
REMOTE Ex LOUDSPEAKER	✗	✗	✓	✗	✓	✗	✓

(*) Gooseneck

Other options available on request

ACCESSORIES FOR MENTOR ORBITAL

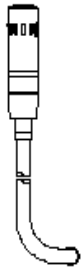

ISMIC 3 Intrinsic safe 300mm goose neck microphone for use with Ex7405/0 (ISMIC/600

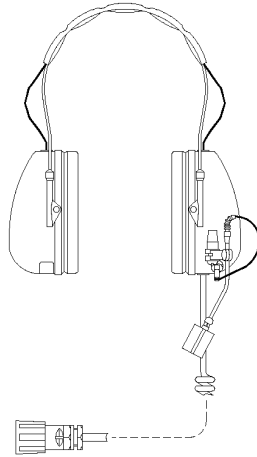

ISMIC 06/07 Intrinsic safe ear Defender Headset & Boom Microphone for use with 7403/0/02

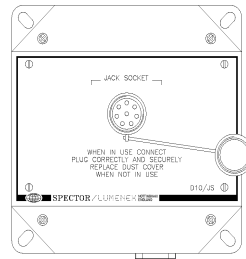

D10/JS Intrinsic Safe Jack Socket Box for use with ISMIC 06/07.

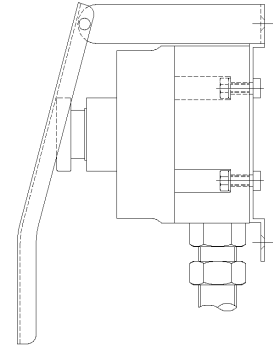

D10/1KS Explosion-proof push to Talk Paddle Switch

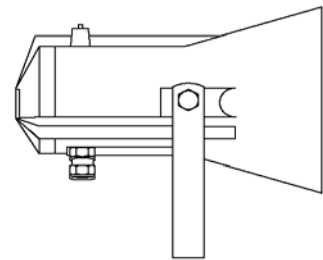

15 Watt Extension Loudspeaker

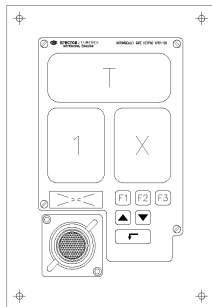

Ex 7450 Flush fit intrinsic safe remote keypad / flush microphone for use with EX7404/0/01

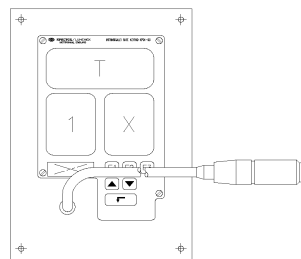

Ex 7451 Flush fit intrinsic safe remote keypad / gooseneck microphone for use with

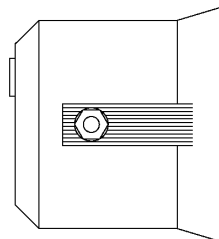

8 Watt Extension Loudspeaker

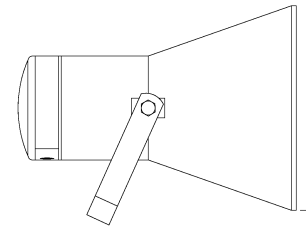

25 Watt Extension Loudspeaker

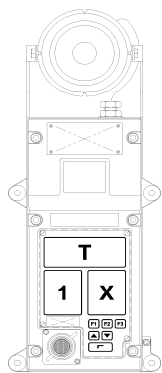

Model N°7400

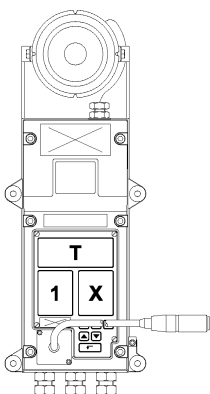

Model N°7401

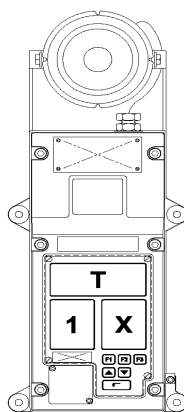

Model N°7406

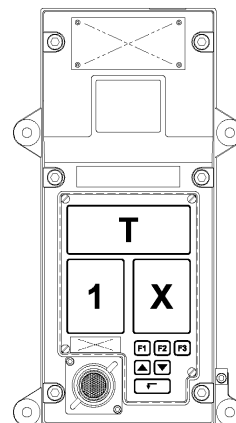

Model N°7407

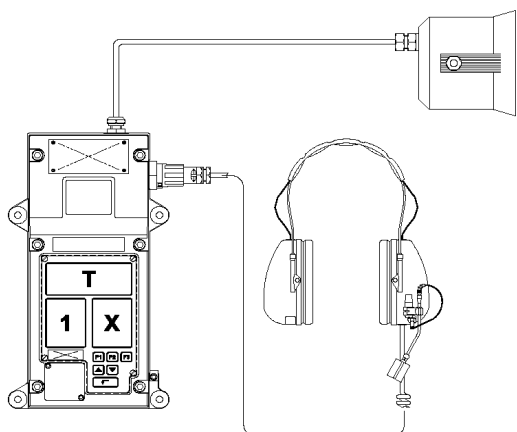

Model N°7403

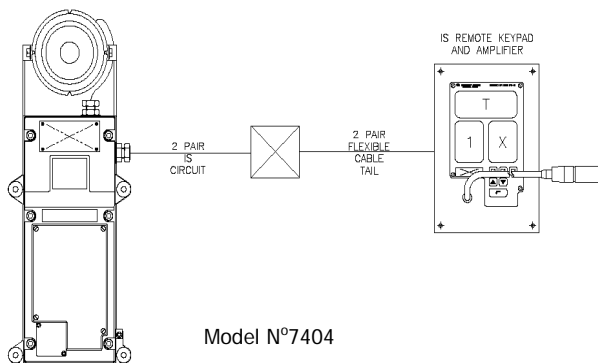

Model N°7404

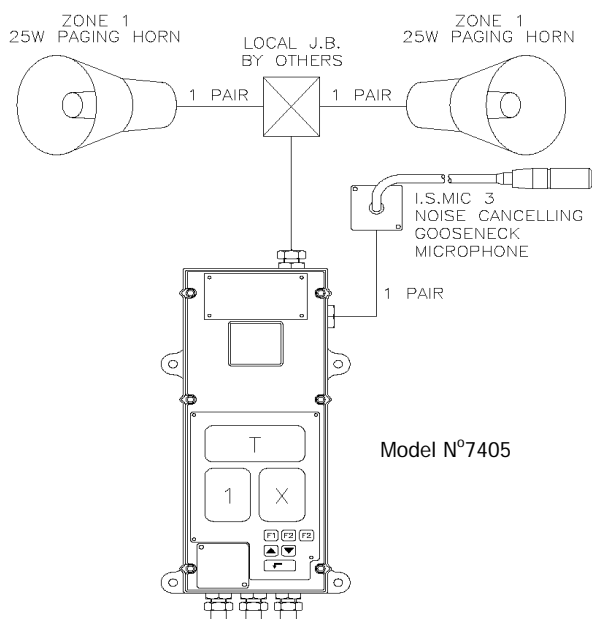

Model N°7405

Mentor Orbital Ex7400 Explosion-proof Station

