

## Mentor Orbital Shout Back

The Mentor Orbital is a Zone 1 certified intercom station which when fitted with "04" SIL facilitates shout back two way communications in a hostile environment.



The 04 configuration is designed to support two intercom positions only: Master and Slave. The Mentor Orbital station is fitted at the Master position whilst a passive horn loudspeaker Assembly is located at the Slave position.

### Master position

This comprises of a Mentor Orbital zone 1 station equipped with 8 watt amplifier local horn loudspeaker. The unit is fitted with an ISMIC3 hyper cardioid noise cancelling goose neck microphone and KP01 series I.S. keypad and optional Zone 1 Ex "push to talk" foot switch. The station can also be fitted with a remote keypad and microphone.

### Shout Back Slave position

This is fitted with a re entrant horn which is arranged to EITHER distribute speech from the master position microphone OR to shout back to the Master Station.

### Operation

Quiescent: No audio broadcast from either slave or master loudspeakers. Master depresses the "X" key on the Mentor Orbital key pad which immediately connects the slave to the master in a "slave talks to master" mode. Audio is now received continuously at the master position FROM the slave hands free. The master position can return speech on a priority basis TO the slave loudspeaker by depressing either "T" on the Mentor Orbital key pad or by depressing a PTT foot switch. Releasing either control facility returns the unit to receiving audio from the slave. To deactivate the link the master unit operator depresses "Reset" [F1] key on the Mentor Orbital key pad.

### Applications

- ✓ Drill Rig - Driller to "Monkey board" direct link communications systems or Driller to "Drill Floor" direct link communications systems
- ✓ Crane Comms

### Key Features & Benefits

- ✓ Noise cancelling microphone at the master position assures highest intelligibility at the slave.
- ✓ Integral status display facilitates service without opening unit.
- ✓ Passive SIMPLE hardware at the slave end reduces maintenance in restricted locations.
- ✓ Simple 2 wire installation low cost rapid commissioning.
- ✓ 20 watt amplifier enables very high sound pressure level outputs, assures speech audibility.

### Mechanical Specification

Weight Approx.	10 Kg
Dimensions Approx.	(mm) 340 (H) x 188 (W) x 116 (D)
Entry	20 mm isometric EEXD cable gland entry
Paint Finish	Epoxy powder coated paint Orange to RAL2000
Hazardous Area	Zone 1 IIBT4

### Electrical Specification

Main Supply Input (to be specified)	24 V DC +/- 20% 110/120 +/- 5% 50/60Hz 220/240 +/- 5% 50/60Hz
Mains Consumption	40VA Max 5VA Quiescent
Output Power	20 Watts (speech) at minimum impedance
Total Output Impedance Minimum	2.5 Ohms
Input sensitivity	10mV RMS
Frequency Response	Tailored 200Hz to 5kHz



# Mentor Orbital Shout Back System

## Local Keypad and Microphone

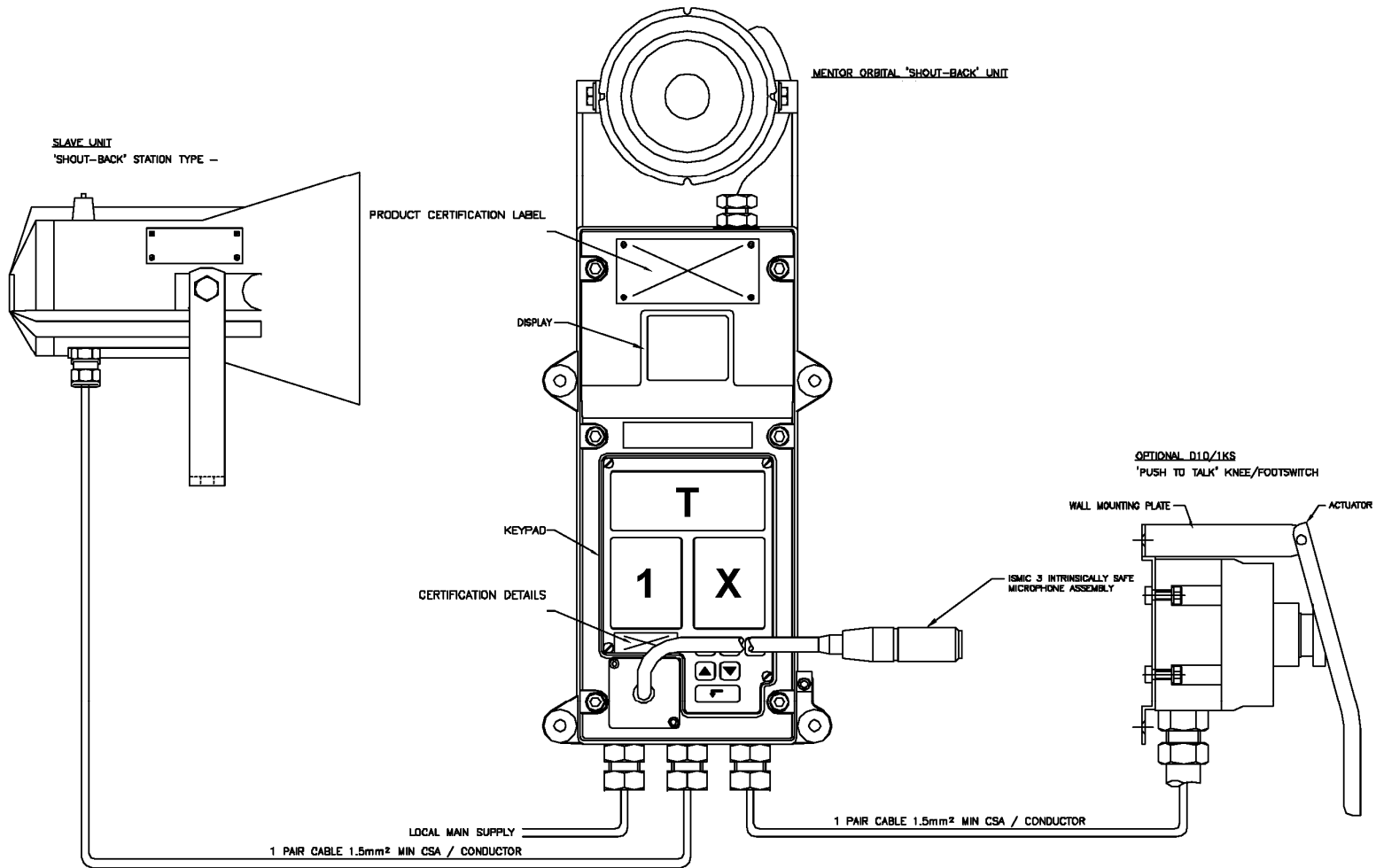

## With Remote Keypad & Microphone

